

FORM NUMBER: 234-0202-00

PRINT DATE: MARCH 1985

SUPERSEDES: IS-110-776

owner / user instructions

FOR SHOWROOM TRUCK

MODEL

110



IMPORTANT

THIS MANUAL HAS BEEN PREPARED TO INSTRUCT USERS IN THE SAFE AND EFFICIENT USE OF FERNO MODEL 110 SHOWROOM TRUCK.

THE MODEL 110 SHOWROOM TRUCK IS DESIGNED TO SUPPORT ONE CASKET FOR THE PURPOSE OF DISPLAY OR FOR TRANSPORT BY ROLLING ON WHEELS.

READ THIS MANUAL COMPLETELY BEFORE USING THE SHOWROOM TRUCK. IF THERE IS ANY INSTRUCTION THAT YOU DO NOT CLEARLY UNDERSTAND, CONTACT CUSTOMER SERVICE FOR ASSISTANCE.

ESTABLISH REGULAR INSPECTION PROCEDURES AND RESPONSIBILITIES TO INSURE PROPER MAINTENANCE AS DESCRIBED.

RETAIN THIS MANUAL FOR FUTURE REFERENCE. INCLUDE IT WITH THE SHOWROOM TRUCK IN THE EVENT OF TRANSFER TO NEW OWNERS OR USERS.

SERIAL NUMBER

DATE RECEIVED

PURCHASED FROM

PRACTICE COMPLETION DATE



EC

REP

FERNO S.r.l.
via B. Zallone, n. 26, 40066
Pieve di Cento, Bologna, Italy
+39.051.6860028 234-3468-02

 **FERNO**
A Division of
FERNO-WASHINGTON, INC.

FERNO
70 Weil Way
Wilmington, OH 45177-9371
(800) 733-3766
(937) 382-1451

COMPONENTS

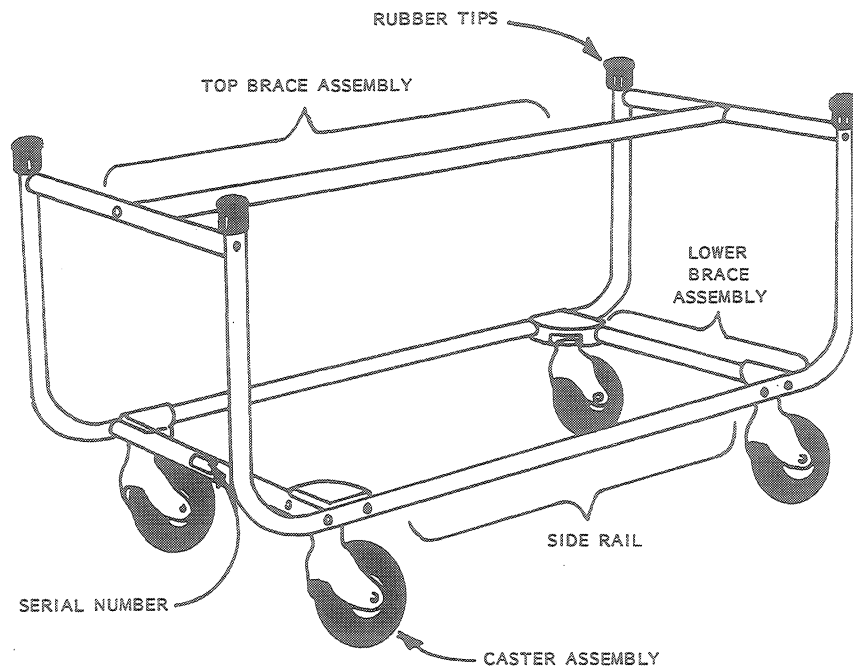

SPECIFICATIONS

LENGTH	44.50 in./113.03 cm.
WIDTH	20 in./ 50.80 cm.
HEIGHT	21.75 in./ 55.25 cm.
WEIGHT	19 lbs./ 8.64 kg.
MAXIMUM LOAD*	1000 lb./454.55 kg.

*Exceeding this limit may cause damage to the showroom truck.

The policy of Ferno-Washington, Inc. is one of continual improvement in design and manufacture. Therefore, specifications are subject to change without notice.

PREPARATION

Uncarton and remove all packing material from the individual parts of the showroom truck. Check for any damage to parts which may have occurred during shipment.

ASSEMBLY

For easier assembly, turn side rail with rubber tips so that the tips are on the ground. Fasten Top Brace to the side rail with two of the head screws provided. Tighten screws securely as shown in Illustration 1.

ILLUSTRATION 1

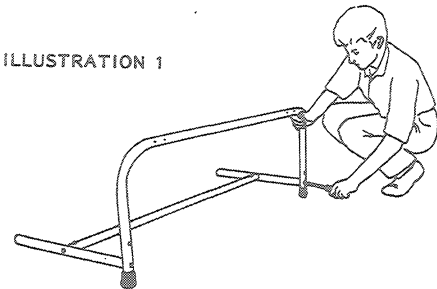

Fasten the other side rail to the top brace assembly and tighten the screws as shown in Illustration 2.

ILLUSTRATION 2

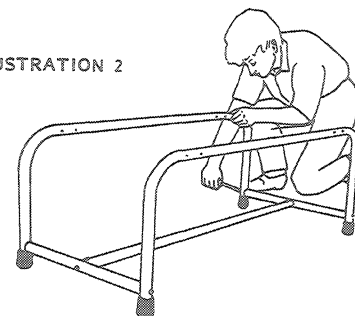

Place one of the lower brace assemblies between the siderails (Illustration 3). The crossstube must face outward toward the end of the truck with the polished surface of the corner casting facing the top of the truck (rubber tipped ends). Line up the two holes on each corner casting with the two holes in the siderail at one end. Insert and start two round head screws, but do not tighten.

ILLUSTRATION 3

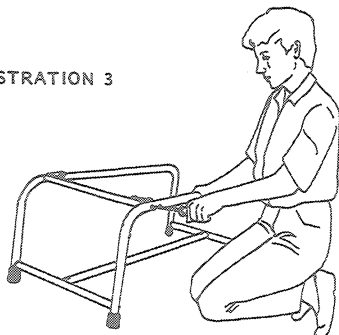

Repeat the procedures for the other end, then tighten all screws securely as shown in Illustration 4.

ILLUSTRATION 4

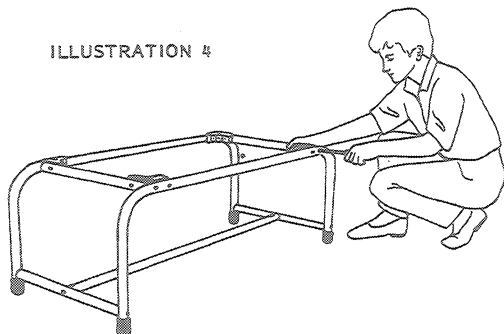

Insert the caster stem pins into the holes in the corner castings. Align the hole in each stem pin with the hole in the side of each corner casting (Illustration 5). Insert a socket head screw and lock washer into each corner casting/stem pin and tighten securely with the hex wrench provided.

ILLUSTRATION 5

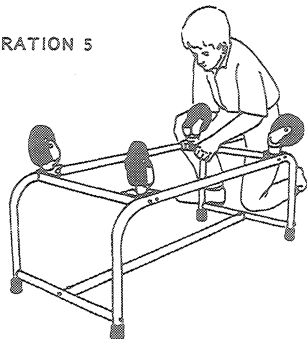

Turn the truck onto its wheels and double-check all screws for tightness before using the truck as shown in Illustration 6.

ILLUSTRATION 6

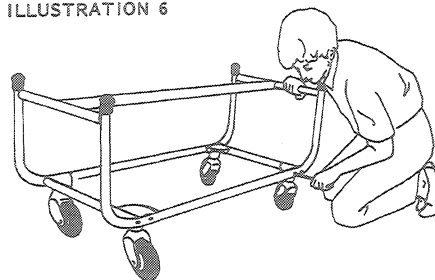

EXAMPLES OF USE

CASKET PLACEMENT: Considering casket length, width, weight, etc., position the casket so that its weight is balanced and evenly distributed to all four wheels. In addition, the casket should be strapped to the truck to aid in security when the truck is rolled.

ROLLING THE TRUCK: The truck is best rolled by pushing from one end. If a low obstacle such as a door sill is encountered, roll up to it, lift/pull front wheels over obstacle and repeat for trailing wheels. **CAUTION: WHEN ROLLING OVER LOW OBSTACLES, LIFT THE TRUCK FRAME, NOT JUST THE CASKET.**

ACCESSORIES

Accessories available for use with the truck include drapes, drape frame attachments, and utility straps. Consult your Ferno mortuary products catalog or distributor for product number and a complete description.

INSPECTION AND MAINTENANCE

One of the most important aspects of any maintenance program is regular inspection. Such inspection should include looking for anything that might affect the integrity of the truck; broken or bent parts, missing fasteners, etc. Inspect at least once a month, more often if it is subjected to unusual stress or heavy use. If at any time the truck does not operate properly or if damage is found, **TAKE IT OUT OF SERVICE** until repair or replacement can be made.

Exposed metal parts are polished, plated, or otherwise treated for easy care and attractive appearance. To protect these surfaces, clean with a mild solvent or soap and water twice a year or as often as needed. Cleaning should be followed by a coat of good wax such as used on automobiles.

CUSTOMER SERVICE

The serial number is stamped on a plate attached to the lower brace assembly on one end of the truck. It should be recorded with other pertinent information in the space provided on the front cover of this manual.

If it becomes necessary to order a replacement part, a reference to both model number and serial number will help us supply the proper parts.

Should questions arise regarding the use or care of this product that are not covered clearly in this manual, our customer service representatives will be happy to assist you. They can be reached directly at the Ferno Division of Ferno-Washington, Inc., 70 Weil Way, Wilmington, Ohio 45177-9371. Phone: (513) 382-1451.

LIMITED WARRANTY

Any product claimed defective and caused by material or workmanship within one year after date of purchase will receive prompt investigation and a fair adjustment.

Obligation is limited to replacement or repair of defective components.

REPLACEMENT PARTS

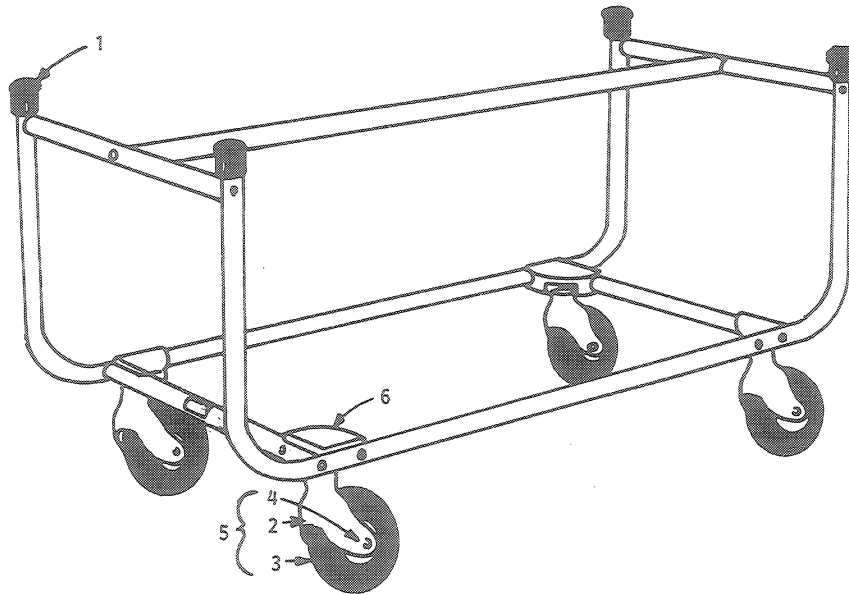

NOTE: PLEASE ORDER BY
PART NUMBER . . . NOT ITEM

ITEM	DESCRIPTION	QTY.	PART NUMBER
1	NO. 20 CRUTCH TIP W/INSERT	PAIR	090-0560-00
2	WHEEL FORK W/BEARINGS & SHANK PIN	1 EA.	090-0070-00
3	5" WHEEL W/BEARINGS, AXLE BOLT & NUT	1 EA.	090-0060-00
4	AXLE BOLT W/NUT	1 EA.	090-0180-00
5	5" SWIVEL CASTER ASSEMBLY, COMPLETE	1 EA.	090-0080-00
6	CORNER BLOCK CASTING	1 EA.	090-2800-00